

# ACRIFIX®

Adhesives and Auxiliaries

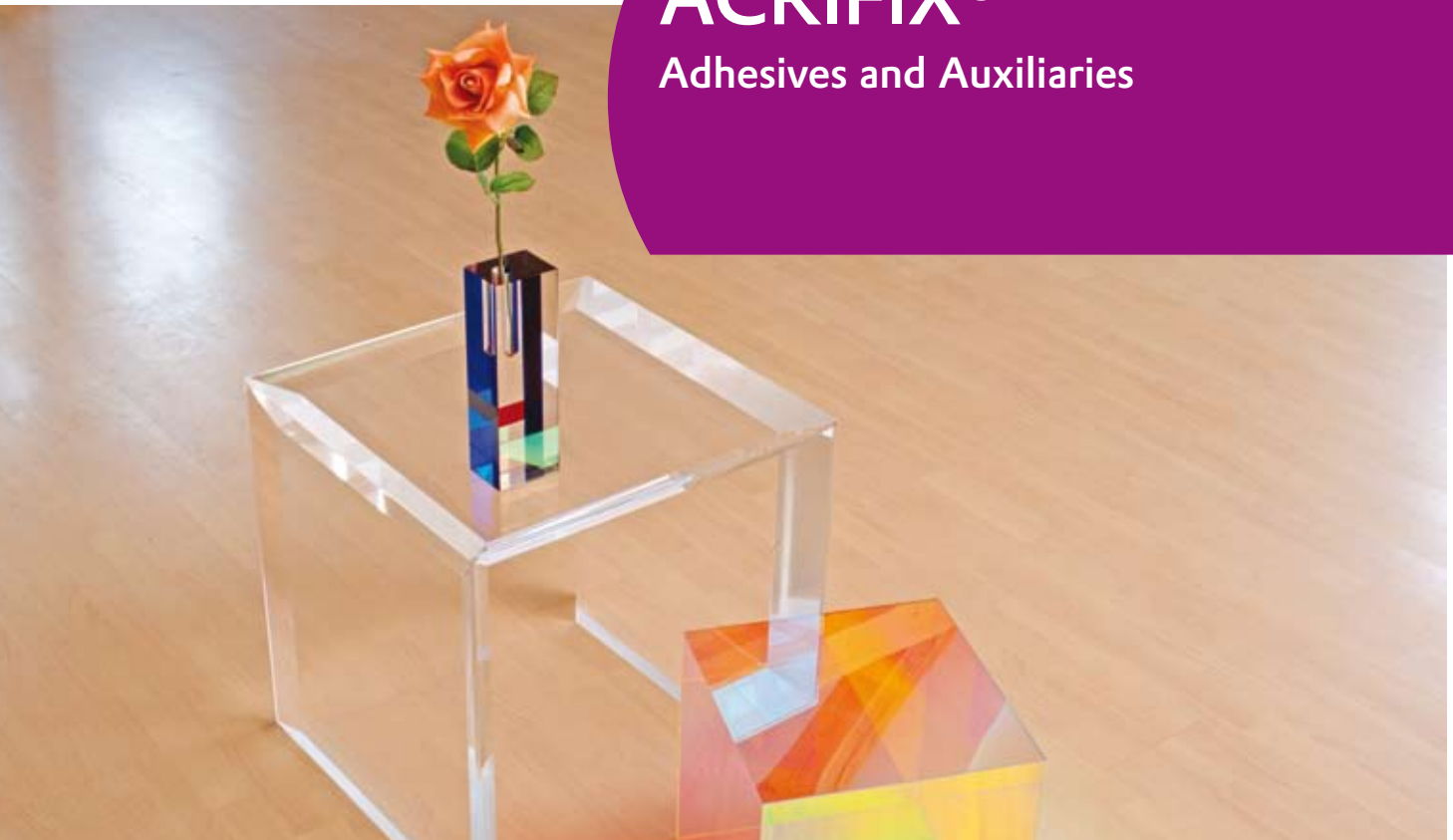

# For a perfect union



PLEXIGLAS® , the world's first acrylic, manufactured by our company, can be joined by a variety of methods. A distinction is made between permanent and non-permanent mechanical joints. The joining method best suited to the application depends on the given requirements.

The most common method for permanent joints is bonding.

Our range of ACRIFIX® adhesives and auxiliaries offers the ideal solution for every application, always providing a perfect union between PLEXIGLAS® and other grades of acrylic.

We divide adhesives into two main groups, reaction adhesives and solvent-based adhesives.



## Table of Contents

Solvent-Based Adhesives	Pages 4–5
Reaction Adhesives	Pages 6–7
Auxiliaries and Colorants	Pages 8–9
Decision Tree	Pages 10–11

## Nomenclature of ACRIFIX® Adhesives

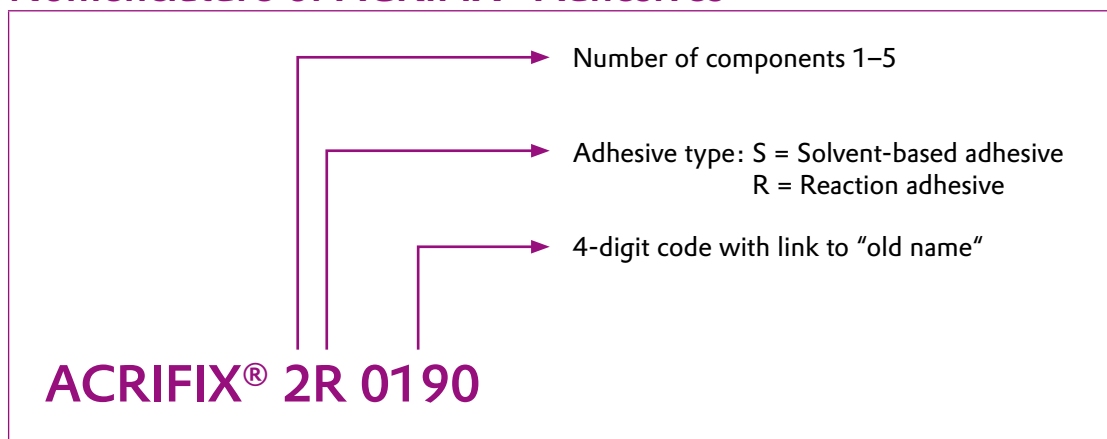

## Nomenclature of ACRIFIX® Auxiliaries

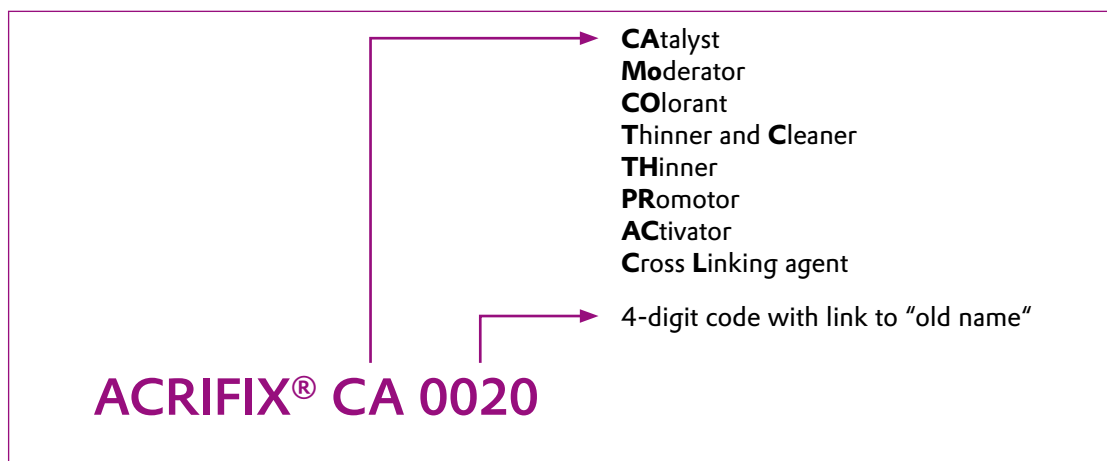

# Solvent-Based Adhesives

Solvent-based adhesives mainly consists of blends of different solvents. Their mode of action is based on partial dissolution of the adherend surface, during which the polymer chains swell and become interlocked. After the parts are joined, the solvents evaporate from the adhesive and diffuse into the material. The interlocked polymer chains contract to form the union. Solvent-based adhesives generally provide good bond strength.

Their advantage lies in the rapid initial bond strength between the bonded parts and their suitability for outdoor applications.



## Solvent-Based Adhesives

Adhesive	ACRIFIX® 1S 0106	ACRIFIX® 1S 0116	ACRIFIX® 1S 0107	ACRIFIX® 1S 0117	ACRIFIX® 1S 0109
<b>Old name</b>	ACRIFIX® 106	ACRIFIX® 116	ACRIFIX® 107	ACRIFIX® 117	ACRIFIX® 109
<b>Type of adhesive</b>	1-component solution adhesive, physically curing, viscous	1-component solution adhesive, physically curing, viscous	1-component solution adhesive, physically curing, thin-bodied	1-component solution adhesive, physically curing, thin-bodied	1-component solution adhesive, physically curing, highly viscous
<b>For sheet material</b>	XT, (GS)	XT	XT	XT	XT, (GS)
<b>Application</b>	quick and easy bonding, butt joints, excellent fit, no area bonding	quick and easy bonding, butt joints, excellent fit, no area bonding	quick and easy bonding, butt joints, very accurate fit required, no area bonding	quick and easy bonding, butt joints, very accurate fit required, no area bonding	edge bonding
<b>Typical applications</b>	displays, store fixtures, mechanical engineering	displays, store fixtures, mechanical engineering	displays, store fixtures, mechanical engineering	displays, store fixtures, mechanical engineering	illuminated signs
<b>Gap-filling</b>	slightly	slightly	no	no	slightly
<b>Appearance of bond</b>	bubbles may form	slight bubble formation possible	bubbles may form	slight bubble formation possible	bubble formation
<b>Weather-resistant</b>	yes	yes	yes	yes	yes
<b>Bond strength</b>	good	very good	good	very good	good
<b>Comments</b>	also for material with slight inherent stress	can be used without applying pressure to bonded parts	also for material with slight inherent stress	optimized for capillary effect, can be used without applying pressure to bonded parts	no capillary effect, immediate skin formation
<b>Initial bond in s</b>	5–30	30–90	5–30	30–90	5–20
<b>Time required before further processing in h</b>	> 3	> 3	> 3	> 3	> 3
<b>Viscosity mPA*s</b>	750–1000	650–900	15	0.8	3000–3400
<b>Contains dichloromethane (suspected carcinogen)</b>	yes	no	yes	no	yes
<b>Safety indications</b>	harmful	harmful, highly flammable	harmful	harmful, highly flammable	harmful
<b>UN number</b>	2810 Class 6.1 III	1133 Class 3 II	2810 Class 6.1 III	1133 Class 3 II	2810 Class 6.1 III
<b>Standard packaging units (other units possible)</b>	5 x 1.2 kg aluminum bottle	5 x 1 kg aluminum bottle 20 x 100 g tube	5 x 1.2 kg aluminum bottle	5 x 1 kg aluminum bottle	5 x 1.2 kg aluminum bottle

XT = extruded acrylic sheet material

GS = cast acrylic sheet material

All solvent-type adhesives are intended solely for professional use.

# Reaction Adhesives

Reaction adhesives based on MMA/PMMA are polymerization adhesives consisting of one or more components. They cure by chemical reaction (polymerization) upon exposure to light or UV radiation, or upon addition of catalysts. They act by partial dissolution of the adherend surface by the monomer. This causes the polymer chains to swell and become interlocked.

During curing, the monomer forms new polymer chains that promote bond strength by additional entanglement. These adhesives are gap-filling and highly suitable for area bonding. They provide very strong bonds of attractive appearance that are generally weather-resistant, depending on the desired adhesive type.

## Reaction adhesives

Adhesive	ACRIFIX® 2R 0190	ACRIFIX® 1R 0192	ACRIFIX® 2R 0195	ACRIFIX® 2R 1200
Old name	ACRIFIX® 190	ACRIFIX® 192	ACRIFIX® 195 DC	AGOVIT® Standard
Type of adhesive	2-component polymerization adhesive, chemically curing, viscous	1-component polymerization adhesive, light-curing, viscous	2-component polymerization adhesive, chemically curing, viscous	2-component polymerization adhesive, chemically curing, highly viscous
For sheet materials	GS and XT	GS and XT Clear	for satin GS and XT surfaces	GS and XT
Application	butt joints, area bonding, fillet joints	butt joints, area bonding, fillet joints	butt joints, area bonding, fillet joints	butt joints, area bonding, fillet joints
Typical applications	furniture, store fixtures, displays, mechanical engineering, model building, aquariums	furniture, store fixtures, displays, mechanical engineering, model building, repairs and DIY	furniture, store fixtures, displays, mechanical engineering, model building	furniture, store fixtures, displays, mechanical engineering, model building
Gap-filling	yes	yes	yes	yes
Appearance of bond	virtually colorless, bubble-free	virtually colorless, bubble-free	bubble-free, translucent white, matte surface similar to SATINICE GS	virtually colorless, bubble-free, more or less smooth surface
Weather-resistant	yes (annealing recommended)	yes (annealing recommended)	yes (annealing recommended)	yes (annealing recommended)
Bond strength	excellent	very good	very good	very good
Comments	can be thinned and colored	-	can be thinned and colored	can be thinned and colored, becomes cloudy when exposed to moisture
Curing	3–6% catalyst ACRIFIX® CA 0020	light-curing or UV	max. 3–6% catalyst ACRIFIX® CA 0020	3–6% catalyst ACRIFIX® CA 0020
Pot life in min with 3% ACRIFIX® CA 0020 / 200 g, 20°C	20–25	5–30, heavily dependent on type and power of illuminant	20–25	15–20
Curing time in min at 3% ACRIFIX® CA 0020	60–70	10–30	60–70	40–50
Time required before further processing in h	> 3	> 3	> 3	> 3
Viscosity mPa*s	1600–2000	1600–2000	not measurable, thixotropic	2800–3600
Safety indications	irritant highly flammable	irritant highly flammable	irritant highly flammable	irritant highly flammable
UN number	1133 Class 3 II	1133 Class 3 II	1133 Class 3 II	1133 Class 3 II
Standard packaging units (other units possible)	5 x 1 kg aluminum bottle 1 x 25 kg composite can 1 x 50 kg hobbock	5 x 1 kg aluminum bottle 20 x 100 g tube	5 x 1 kg plastic bottle 1 x 25 kg hobbock	5 x 1 kg aluminum bottle 1 x 25 kg composite can

XT = extruded acrylic sheet material

GS = cast acrylic sheet material

All reaction -type adhesives are intended solely for professional use.



Market launch from third quarter 2008

	<b>ACRIFIX® 2R 1900</b>	<b>ACRIFIX® 2R 1074</b>	<b>ACRIFIX® 5R 0194</b>	<b>ACRIFIX® 1R 0350</b>	<b>ACRIFIX® 1R 0310</b>
	AGOVIT® 1900	AGOVIT® 1074	ACRIFIX® 194		
	2-component polymerization adhesive, chemically curing, low viscosity	2-component polymerization adhesive, chemically curing, low viscosity	5-component polymerization adhesive, chemically curing, viscous	rapid 1-component polymerization adhesive, UV-curing, highly viscous	rapid 1-component polymerization adhesive, UV-curing, low viscosity
	GS and XT	GS and XT	GS and XT	GS and XT Clear	GS and XT Clear
	butt joints, area bonding, fillet joints	butt joints, area bonding, fillet joints	for joints up to 6mm thick, butt joints, area bonding, fillet joints	area bonding, fillet joints	area bonding, butt joints, laminating adhesive
	furniture, store fixtures, displays, mechanical engineering, model building	furniture, store fixtures, displays, mechanical engineering, model building	especially developed for aquarium building and block bonding, can be used for making furniture and store fixtures	caravan windows, displays, store fixtures, tradeshow booths, mechanical engineering	caravan windows, displays, store fixtures, tradeshow booths, mechanical engineering
	yes	yes	yes	yes	yes
	virtually colorless, bubble-free, more or less smooth surface	virtually colorless, bubble-free, smooth surface	virtually colorless, bubble-free, smooth surface	virtually colorless, bubble-free, slightly cloudy	virtually colorless, bubble-free, slightly cloudy
	yes (annealing recommended)	yes (annealing recommended)	yes (annealing recommended)	yes (annealing recommended)	yes (annealing recommended)
	very good	good	excellent	good	good
	can be thinned and colored, becomes cloudy when exposed to moisture	can be thinned and colored, becomes cloudy when exposed to moisture	can be thinned by max. 20% with ACRIFIX® TC 0030	mechanically applicable adhesive that is rubbery-elastic after curing	mechanically applicable adhesive that is rubbery-elastic after curing
	3-6% catalyst ACRIFIX® CA 0020	3-6% catalyst ACRIFIX® CA 0020	0.5% catalyst ACRIFIX® CA 0030 0.3% Promotor ACRIFIX® PR 0031 3.0% Activator ACRIFIX® AC 0032 0.5% Cross- Linking Agent ACRIFIX® CL 0033	UV-A/B-curing	UV-A/B-curing
	15-20	15-20	30 (60 with 20% dilution)	not applicable	not applicable
	40-50	40-50	70-90 (150-240 with 20% dilution)	3-5 in thin layer	3-5 in thin layer t
	> 3	> 3	> 24	> 1	> 1
	450-550	450-550	1600-2100 (450-550 with 20% dilution)	4500-6000	500-700
	irritant highly flammable	irritant highly flammable	irritant highly flammable	irritant highly flammable	irritant highly flammable
	1133 Class 3 II	1133 Class 3 II	1133 Class 3 II	1133 Class 3 II	1133 Class 3 II
	5 x 1 kg aluminum bottle 1 x 25 composite can	5 x 1 kg aluminum bottle 1 x 25 composite can	special grade produced on request	5 x 1 kg aluminum bottle 1 x 25 composite can	5 x 1 kg aluminum bottle 1 x 25 composite can

# Auxiliaries and Colorants

Auxiliaries and colorants are required to prepare adherends in the appropriate way or optimize adhesives for their application, e.g. by adjusting the viscosity to the given requirements. Colorants make it possible to vary the color of the adhesive and adapt it to the color of the sheet material

## Auxiliaries and Colorants

Auxiliary	ACRIFIX® CA 0020	ACRIFIX® MO 0070	ACRIFIX® CO	ACRIFIX® TC 0030	ACRIFIX® TH 0032
<b>Old name</b>	CATALYST 20	REACTION MODERATOR 70	COLORANT	THINNER AND CLEANER 30	THINNER 32
<b>Description</b>	clear, slightly yellowish liquid based on dibenzoyl peroxide	clear purplish liquid	colored pasty compound based on organic and inorganic pigments in plasticizer	clear, colorless liquid based on methyl methacrylate	clear, slightly yellowish liquid based on methyl methacrylate with activator
<b>Function</b>	hardener for polymerization adhesives	reaction moderator for polymerization adhesives	for coloring polymerization adhesives	for thinning polymerization adhesives and cleaning adherends	for thinning polymerization adhesives
<b>For use with adhesive</b>	ACRIFIX® 2R 0190, 2R 0195; 2R 1200, 2R 1900, 2R 1074	ACRIFIX® 2R 0190	ACRIFIX® 2R 0190, 2R 0195; 2R 1200, 2R 1900, 2R 1074	all polymerization adhesives	ACRIFIX® 2R 0190
<b>Comments</b>	do not store under 12°C	discoloration does not affect functionality	Black CO 9073 White CO W074 Red CO 3075 Blue CO 5076 Yellow CO 1077	for thinning ≤ 10%	for thinning > 10%
<b>Viscosity mPA*s</b>	approx. 50	30	pasty	0,6	0,6
<b>Safety indications</b>	irritant oxidizing toxic	not a hazardous substance	not a hazardous substance	irritant oxidizing toxic	irritant oxidizing toxic
<b>UN number</b>	not applicable	not applicable	not applicable	1247 Class 3 II	1247 Class 3 II
<b>Standard packaging units (other units possible)</b>	5 x 60 g aluminum bottle 5 x 1 kg aluminum bottle 30 kg composite can	5 x 60 g aluminum bottle	500 g PE can	5 x 1 kg aluminum bottle 1 x 25 kg composite can	5 x 1 kg aluminum bottle

Auxiliaries and colorants are only suitable for professional use.



## Auxiliaries and Colorants

Auxiliary	ACRIFIX® CA 0030	ACRIFIX® PR 0031	ACRIFIX® AC 0032	ACRIFIX® CL 0033
Old name	CATALYST 20	PROMOTOR 31	ACTIVATOR 32	CROSSLINKING AGENT 33
Description	clear, colorless liquid based on ketone peroxide	clear colorless liquid based on a mercaptane	clear, slightly greenish liquid based on a vanadium salt	slightly yellowish liquid/paste derived from multifunctional acrylates
Function	hardener for polymerization adhesives	additional accelerator	activator for polymerization adhesive	crosslinking agent for polymerization adhesive
For use with adhesive	ACRIFIX® 2R 0194	ACRIFIX® 2R 0194	ACRIFIX® 2R 0194	ACRIFIX® 2R 0194
Comments	avoid direct contact with activator ACRIFIX® AC 0032		avoid direct contact with catalyst ACRIFIX® CA 0030 and CA 0020	avoid direct contact with catalyst ACRIFIX® CA 0030 and CA 0020, may crystallize at room temperature. Liquefies again at 40–50 °C
Viscosity mPA*s	16	40	40	350 at 38 °C
Safety indications	oxidizing corrosive	not a hazardous substance	corrosive	harmful
UN number	3105 Class 5.2 II	not applicable	1760 Class 8 III	none
Standard packaging units (other units possible)	1 x 20 g glass bottle 1 x 100 g glass bottle 1 x 200 g glass bottle	1 x 20 g glass bottle 1 x 100 g glass bottle 1 x 200 g glass bottle	1 x 100 g glass bottle 1 x 200 g glass bottle 1 x 1 kg plastic bottle	1 x 20 g glass bottle 1 x 100 g glass bottle 1 x 200 g glass bottle

Auxiliaries and colorants are only suitable for professional use.



# Decision Tree

## V-Groove (Fillet Joint)

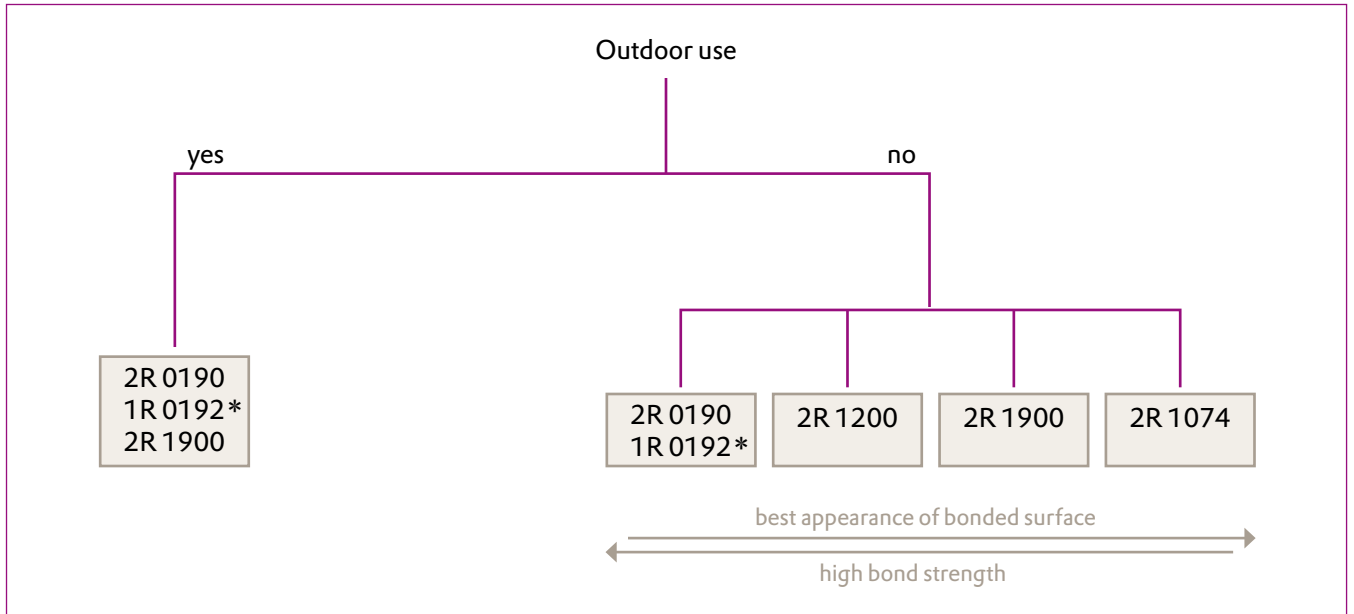

## Area Bonding

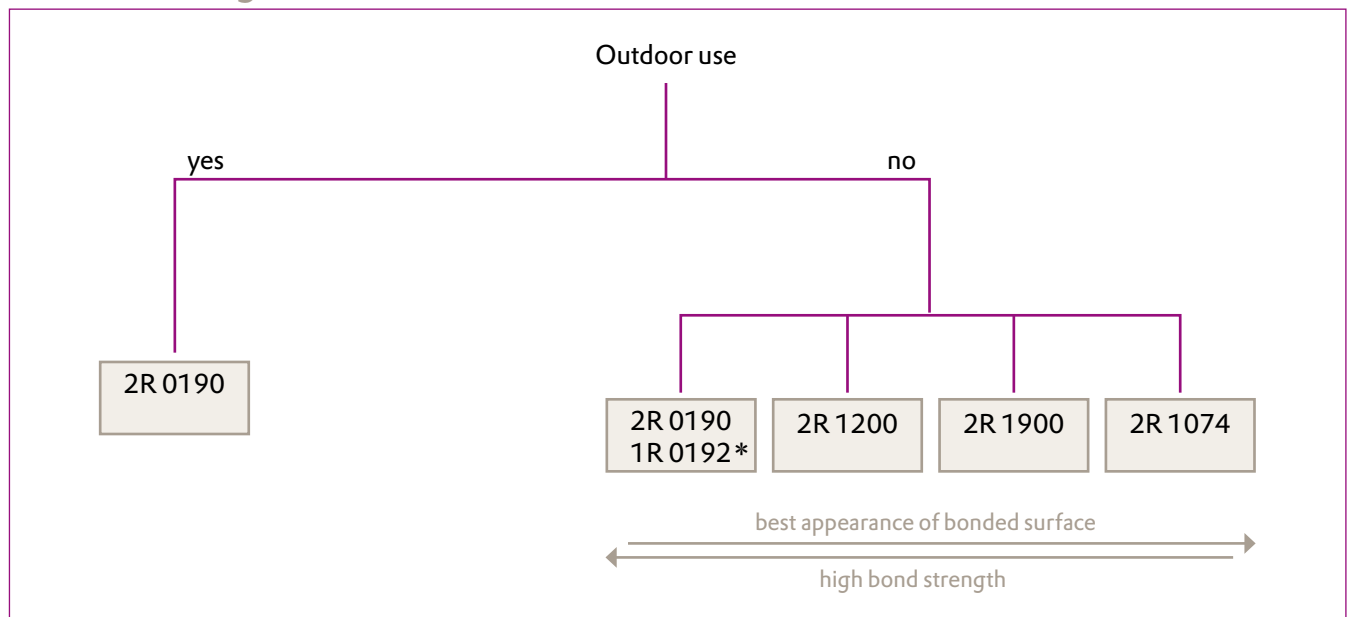

## Satin Bonded Surfaces

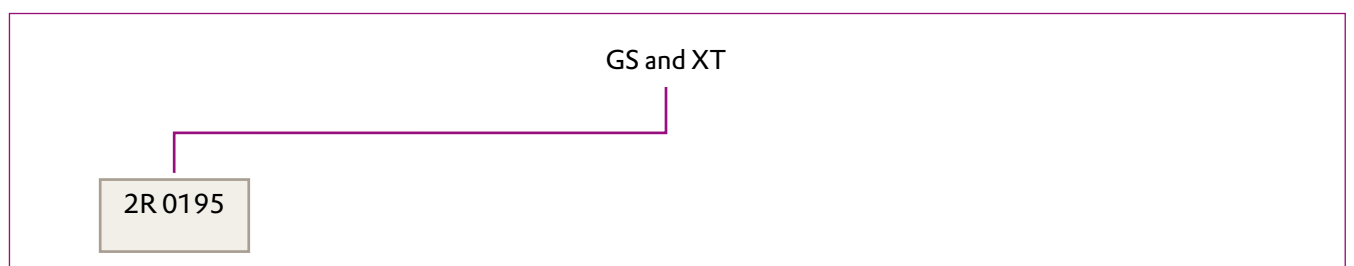

\* UV-curing adhesive



® = registered trademark

ACRIFIX®  
is a registered trademark of  
Evonik Röhm GmbH, Darmstadt, Germany.

Certified to DIN EN ISO 9001 (quality)  
and DIN EN ISO 14001 (environment)

This information and all further technical advice is based on our present knowledge and experience. However, it implies no liability or other legal responsibility on our part, also with regard to existing third party intellectual property rights, especially patent rights. In particular, no warranty, whether express or implied, or guarantee of product properties in the legal sense is intended or implied. We reserve the right to make any changes according to technological progress or further developments. The customer is not released from the obligation to conduct careful inspection and testing of incoming goods. Performance of the product described herein should be verified by testing, which should be carried out only by qualified experts in the sole responsibility of a customer. Reference to trade names used by other companies is neither a recommendation, nor does it imply that similar products could not be used.

Ref. No. 191-1 March 2009  
30/0309/09703 (en)



**EVONIK**  
INDUSTRIES

Business Unit  
Performance Polymers

Evonik Röhm GmbH  
Kirschenallee  
64293 Darmstadt  
Germany

info@plexiglas.net  
www.plexiglas.net  
www.evonik.com  
www.plexiglas-shop.com

**Evonik. Power to create.**